



Rewarding Learning

ADVANCED SUBSIDIARY (AS)
General Certificate of Education

Centre Number

--	--	--	--	--

Candidate Number

--	--	--	--	--

Physics

Assessment Unit AS 3A

assessing

Practical Techniques
and Data Analysis



SPH31

[SPH31]

Assessment

TIME

1 hour.

Assessment Level of Control:

Tick the relevant box (✓)

Controlled Conditions	
Other	

INSTRUCTIONS TO CANDIDATES

Write your Centre Number and Candidate Number in the spaces provided at the top of this page.

Answer **all** the questions in this booklet. Rough work and calculations must also be done in this booklet. Except where instructed, do **not** describe the apparatus or experimental procedures. The Teacher/Supervisor will tell you the order in which you are to answer the questions. One hour is to be spent on four short experimental tests.

After 12 minutes you must stop using the apparatus so that it can be rearranged for the next candidate. At 14 minutes you will be instructed to move to the station for the next question.

At the end of the test a 4 minute period will be provided for you to complete your answer to any question, but you will not have access to the apparatus during this time.

INFORMATION FOR CANDIDATES

The total mark for this paper is 40.

Figures in brackets printed down the right-hand side of pages indicate the marks awarded to each question or part question.

You may use an electronic calculator.

For Examiner's use only		
Question Number	Marks	Remark
1		
2		
3		
4		

Total Marks		
--------------------	--	--

1 In this experiment you will determine a value for the speed of sound in air.

You are provided with a cylinder containing water, a moveable open-ended resonance tube and a half metre rule. **The half metre rule is clamped and is not to be moved.** In addition, you are provided with two tuning forks, with their frequencies clearly labelled. A diagram of the apparatus is shown in **Fig. 1.1**.

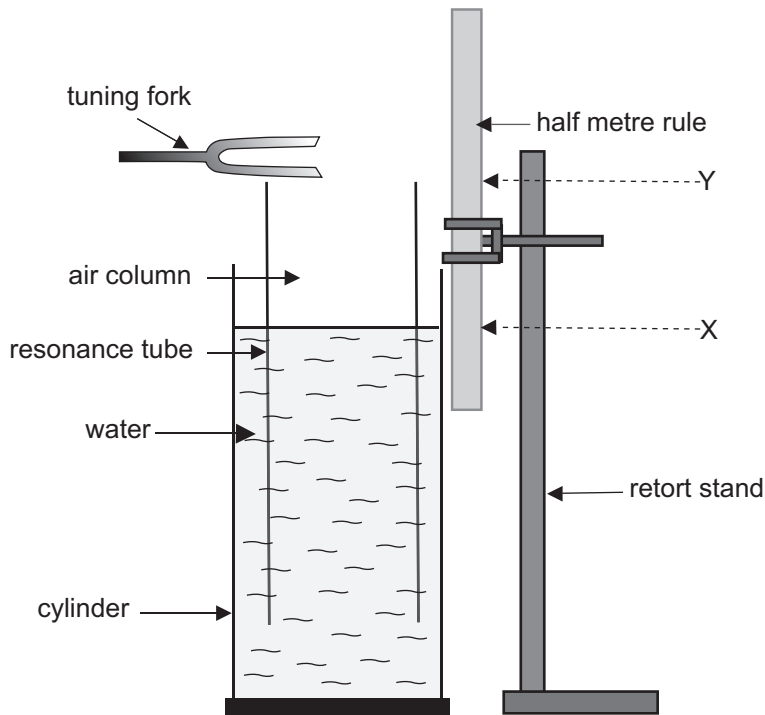

Fig. 1.1

(a) Strike the tuning fork of frequency 320 Hz on the rubber bung and hold it above the upper end of the resonance tube. Slowly raise both the vibrating tuning fork and resonance tube and stop when the first mode of vibration is reached.

(i) How do you know when the first mode of vibration is reached?

[1]

Examiner Only	
Marks	Remark

BLANK PAGE

(Questions continue overleaf)

- 3 In this experiment you will investigate the relationship between the period of oscillation T of a long, thin, flat strip of wood known as a lath, and its length L .

The apparatus has been set up as shown in **Fig. 3.1**.

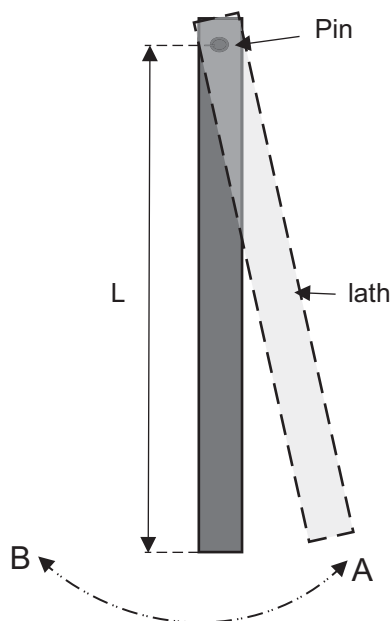

Fig. 3.1

Two laths of different length L have been provided.

The length of the lath is measured between the point of suspension on the pin and the end of the lath, as shown in **Fig. 3.1**.

The lath is set into oscillation by displacing it a small distance to one side, as shown in **Fig. 3.1**.

The period of oscillation T is the time taken for the lath to swing from A to B and back to A.

- (a) The longer lath has been placed on the pin.

Measure the length L of the lath and record it in **Table 3.1**.

Find a reliable value of the period of oscillation T for this lath.

Repeat this procedure for the other lath.

Record all your readings in **Table 3.1**.

[6]

Examiner Only

Marks Remark

- (b) (i) Set the ball at the marker as shown in **Fig. 4.1**. Use the stopclock provided to measure sufficient readings to determine the average time the ball takes to roll down the slope. Record all your readings in **Table 4.1**.

Table 4.1

Time/s	

Average time = _____ s [2]

- (ii) Calculate the average speed of the ball in ms^{-1} .

Average speed = _____ ms^{-1} [1]

- (c) (i) Calculate the change in gravitational potential energy ΔGPE of the ball using **Equation 4.1**

$$\Delta\text{GPE} = mgh \quad \text{Equation 4.1}$$

where m is the mass of the ball, g is the acceleration of free fall 9.81 ms^{-2} and h is 0.10 m .

$\Delta\text{GPE} =$ _____ J [2]

Examiner Only	
Marks	Remark

- (ii) Calculate the kinetic energy KE gained by the ball using **Equation 4.2**

$$KE = \frac{1}{2}mv^2 \quad \text{Equation 4.2}$$

where m is the mass of the ball and v is the final speed of the ball.

KE = _____ J [2]

- (iii) Calculate the percentage efficiency of the conversion from gravitational potential energy to kinetic energy when the ball rolls down this slope.

Percentage efficiency = _____ % [1]

Examiner Only	
Marks	Remark

THIS IS THE END OF THE QUESTION PAPER

Permission to reproduce all copyright material has been applied for.
In some cases, efforts to contact copyright holders may have been unsuccessful and CCEA
will be happy to rectify any omissions of acknowledgement in future if notified.